

Instruction Manual to

BS14 Model Wood Cutting Band Saw



CE

Please read the manual before using it

IT'S IMPORTANT THAT YOU READ THE RETIRE MANUAL TO BECOME FAMILIAR WITH THE UNIT BEFORE YOU BEGIN ASSEMBLY.

1. TECHNICAL SPECIFICATIONS

NO	ITEMS	UNIT	TYPE	
			BS14	
1	Saw wheel diameter	mm	350	
2	Table pivot capacity	°	0-45 °	
3	Processing Scope	Max height	mm	160
		Max width	mm	335
4	Length of saw blade	mm	2400	
	Width of saw blade	mm	6-15	
5	Line speed of saw blade	m/s	12;10	
6	Necessary Motor	Power	HP/Kw	1;0.75
		Voltage	V	230;110
		Frequency	Hz	50;60
		Rotational speed	RPM	1400;1700

2. PACKAGING

Accessories

- 1) mitre gauge(according to the customers' requirement)
- 2) manual
- 3) saw mouth board

3. IMPORTANT SAFETY INSTRUCTIONS!

READ ALL INSTRUCTIONS BEFORE USING THIS PRODUCT!

3.1 WORK AREA

To Avoid of personal injury, equipment damage, fire and shock, make sure your work area is:

- Free of damp, wet or rainy conditions
- Free of flammable gasses or liquids
- Childproof-use padlocks and master switches when not in use.
- Well-lit
- Clean and uncluttered
- Well –ventilated

3.2 THE OPERATOR

COMMON SENSE AND CAUTION ARE FACTORS WHICH CANNOT BE BUILT INTO ANY PRODUCT. THESE FACTORS MUST BE SUPPLIED BY THE OPERATOR. PLEASE REMAMBER:

- Prevent body contact with grounded surfaces such as pipes or radiators.
- Stay alert. Never operate equipment if you are tired.
- Do not operate the product is under the influence of alcohol or drugs. Read warning labels on prescriptions to determine if your judgment reflexes might be impaired.
- Do not wear loose clothing or jewelry as they can be caught in moving parts.

—Not-skid footwear is recommended.

—Wear restrictive hair covering to contain long hair.

—Use eye and ear protection. Always wear:

ANSI approved dust mask or respirator when working around metal wood ,and chemical dusts and mists.

A full face shield if you are producing metal or wood filings.

Ear protectors

—Maintain proper footing and balance at all times.

—Do not reach over or across running machines.

3.3 BEFORE OPERATING

—Know the machine. Learn its applications and limitations as well as the specific potential hazards.

—Check for damage. If part of the machine is damaged. It should be carefully inspected to ensure that it can perform its intended function correctly. If in double the part should be replaced.

—Be sure the switch is OFF before plugging in.

—Make sure tool has been cleaned and properly lubricated.

—Check for damaged parts before using any tool, any part that appears damaged should be carefully checked to determine that it will operate properly and perform its intended function.

—Check for alignment and binding of all moving parts broken parts or mounting fixtures and any other condition that may affect proper operation. Any part that id damaged should be properly repaired replaced by a qualified technician.

—Do not use the tool if any switch does not turn off and on properly.

3.4 SPECIAL SAFETY RULES FOR BAND SAWS

—Adjusting the upper guide of saw blade to make it higher about 1/8" than the cut material.

—Saw after the machine rolling regularly select different speed of filling material according to the different hardness and thickness of wood. Forbid filling material too fast.

—Check for proper blade size and type make sure that blade's tension and tacking are properly adjusted according to the instruction to change saw blade.

—The worker shouldn't leave the place when the machine is working. Don't forget to cut off the main power source when not working.

—Use foot bolt to forbid the machine learning to the ground.

4. GROUNDING/VOLTAGE

4.1 INSTRUCTION OF GROUNDING

—This machine provided power outlet and cable. And there is grounding wire on it. The contact of outlet on the sawing machine must connect with the case of sawing machine. The other outlet should be correctly plug in the standard outlet should be installed correctly and connected with the earth.

—If grounding wire can't be connected properly, it may be struck, Change or repair cable or outlet don't connect the grounding line wrongly.

—When the cable is damaged, change or repair it in time.

4.2 CONNECTIONS OF POWER SOURCE

The single electric current should be used. The protector should be set in order to protect. Assure that the line voltage should agree with the motor voltage on it's plate before running machine.

4.3 WIRE DIAGRAMS (MJ343B, MJ343C)

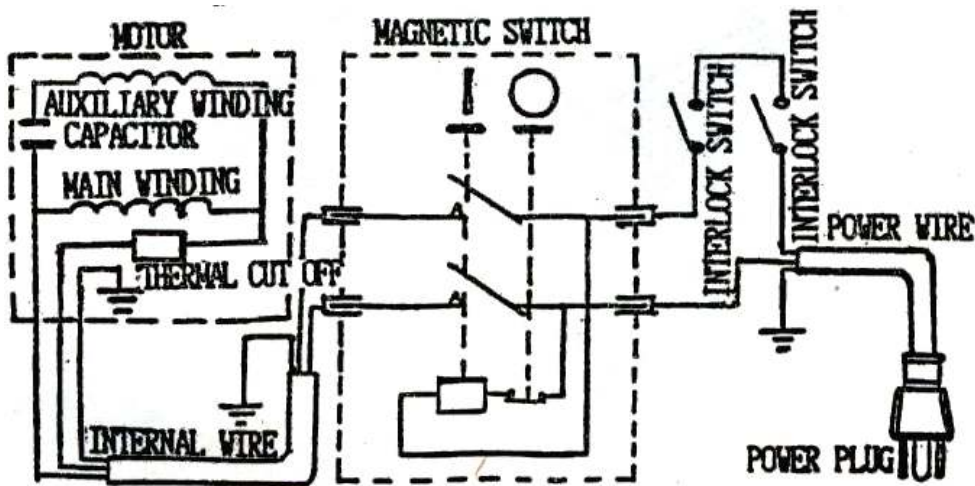

NOTICE: WE SUPPLY YOU INTERLOCK SWITCHES ONLY WHEN YOU PLACE AN ORDER.

5. TABLE'S TINSTALLING AND ADJUDTING

5.1 INSTALLING TABLE see Fig.(1)

Install worktable (#83) according to Fig.(1). Fix the saw mouth (#85) into the center of worktable.

Connect the guide board (#87) with the table use four butterfly screw bolts as Fig.(1). Then make the square neck bolt (#76) plug in the side guide board through strip-shaper washer (#75). Fix the upper guide board (#79) and side guide board with washer and butterfly nut.

Put the upper board on the right side of saw blade. Loosen the nuts (#77). Take off the upper guide board and loosen the butterfly nut (#76). Slip the stand of upper guide board (#74) to the right side of saw blade (#36). Then fix the upper guide board on the other side of the stand of upper guide board.

EXERCISE CAUTION! Never force the material into the band saw. You will become familiar with the saw's features from practice and use. If possible, practice sawing with a piece of wood.

5.2 ADJUDTING TABLE ANGLE see Fig.(2)

- 1) If working table is to be used at an angle, make sure to install the angle core board.
- 2) Loosen butterfly nut(#32) and adjust working table to the desired angle using the numbers on the rotating angle rule(#88).
- 3) Tighten butterfly nut (#73) securely so that the working table will not move during operation.

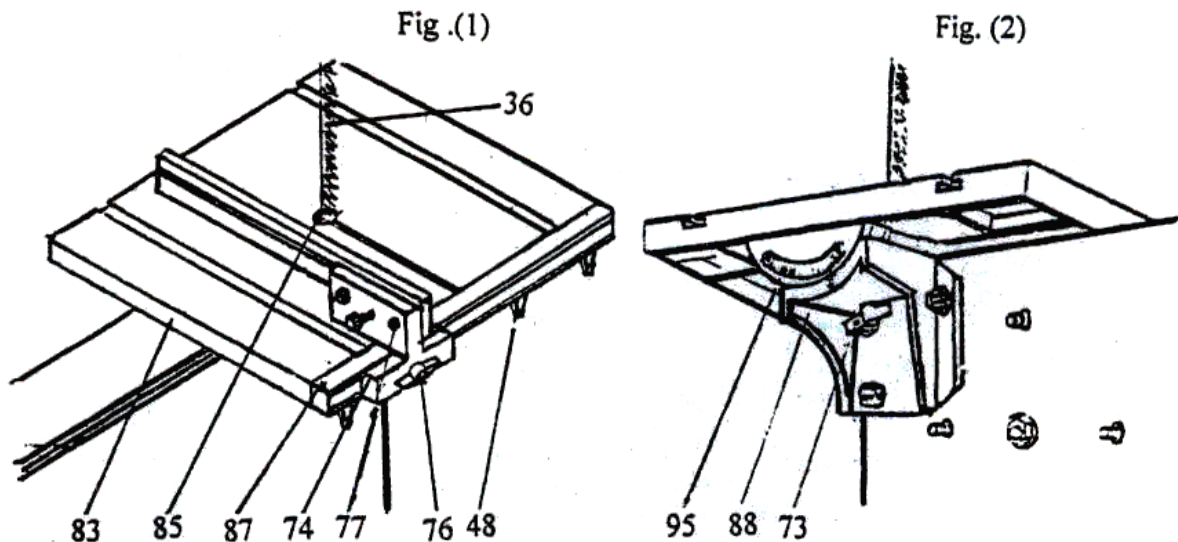

6. MANUAL TO SAW BLADE

6.1 TO CHANGE SAW BLADE

MAKE SURE SWITCH IN "OFF" POSITION. AND UNPLUG THE SANDER BEFORE PERFORMING ANY OF THE STEPS BELOW.

- 1) First open the upper door and lower door (#8) & (#9), then loosen hand wheel (#20). Fig.(3)
- 2) Remove side guide board (#87) and saw blade (#36). Fig.(1)
- 3) Select and install the new one.
- 4) Install the side guide board (#87).
- 5) Roll the hand wheel (#20) to tighten the saw blade. Give the saw blade 3kg side pressure tensile deformation is about 8mm. The tension of saw blade is moderate.
- 6) Roll the upper saw blade with hand, adjust the running track of saw blade(#36) in the protective case by rolling the flower handle (#33) of the back of upper saw wheel housing as Fig.(3) in order to make the saw blade run in the center.
 - a) BLADE GUIDING see Fig.(4)

The saw blades guide of this band saw model MJ34 ensure an exact guiding of the blade for clean cuts. When using narrow blades ensure that the lower blade guide positively supports the blade from both sides and the rear.

Set the bearings (#111) of the upper blade guide and the guide axles (#66) to within approx. 0.5mm of the blade, and the large thrust bearing (#109), (#62) against the back of the blade just clear of it. Do not set the bearing too close, as the friction generates heat, which may have an adverse effect on the bearings and the saw blade as well.

- b) SETTING THE CUTTING HEIGHT see Fig.(4)

The upper blade guide should always be set as close as practical against the wok. To adjust, loosen the position (1) of the wing nut at the side of the upper wheel housing , and set the blade guide to the required height.

Tighten wing nut after setting.

Fig.(3)

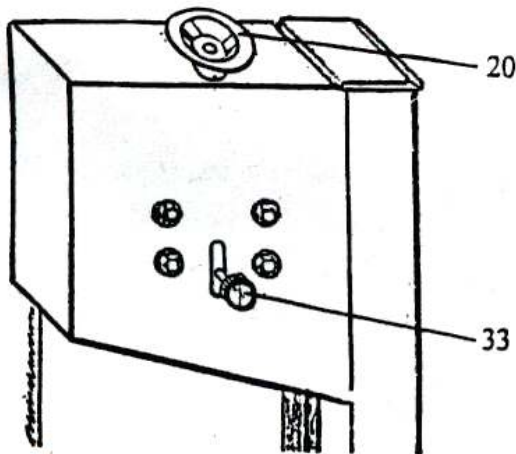
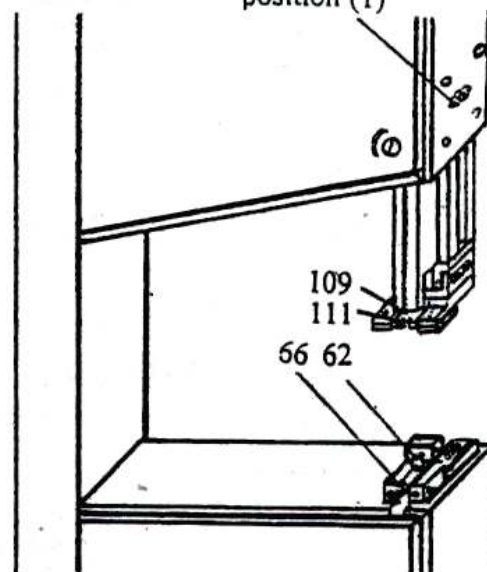
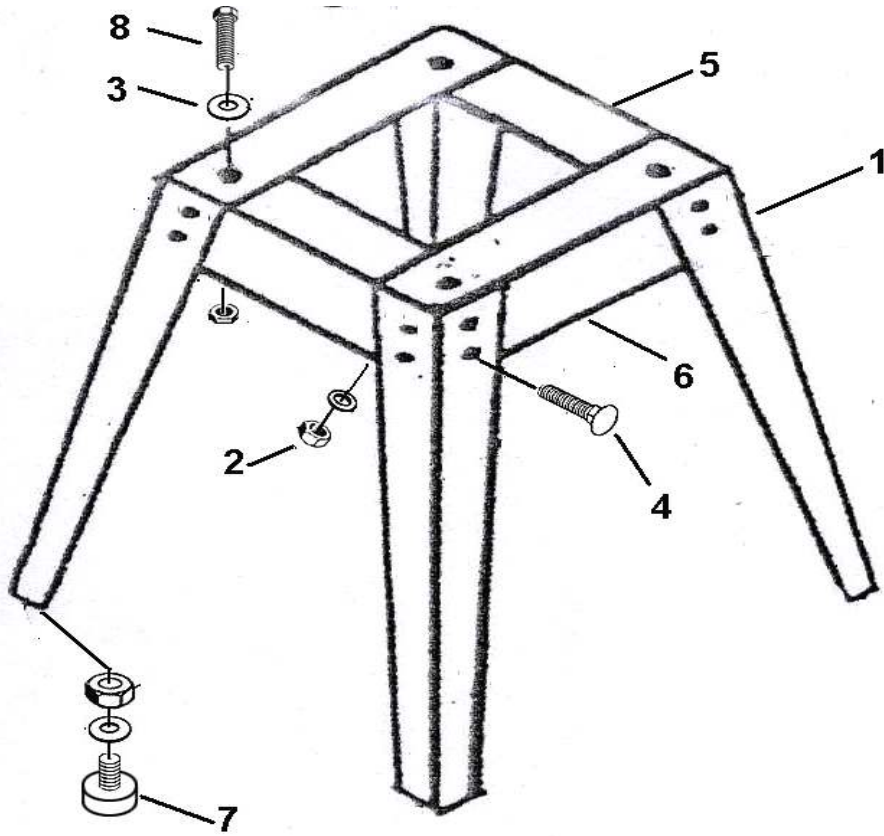

Fig.(4)
position (1)



7. BREAKDOWN AND THE METHODS OF FIXING BREAKDOWN

Items	Reason	Fixing Method
1. The motor can not start.	<ol style="list-style-type: none"> 1. The power isn't on. 2. The fuse of electric circuit has blown. 3. The electric cable is damaged. 4. The switch isn't "on". 5. The motor is damaged. 	<ol style="list-style-type: none"> 1. Check all the electric circuit. 2. Change the fuse. 3. Repair or change the cable. 4. Check the switch. 5. Change the motor.
2. The saw blade can not cut or the cutting speed is slow.	<ol style="list-style-type: none"> 1. The saw blade is installed on the contrary, the saw teeth cut on the same direction. 2. There are some hard things such as iron or stone etc in the saw teeth. 3. The saw teeth is passive for long time using. 	<ol style="list-style-type: none"> 1. Turn over the saw blade and install it again. 2. Manage to remove the hard things, resharpen the saw teeth. 3. Repair and gring the saw teeth to make it sharp.
3. Slipping saw blade.	<ol style="list-style-type: none"> 1. The saw blade is not straight. 2. The upper wheel doesn't parallel with the lower one, 3. The guiding installation of the saw blade has deflected. 	<ol style="list-style-type: none"> 1. Reinstall the up-to –standard saw blade. 2. Adjust the upper wheel to make it parallel with the lower one. 3. Adjust the guiding installation to make its running direction as same as the saw blade's
4. The saw blade is broken.	<ol style="list-style-type: none"> 1. The direction of the guiding board is deflected. 2. The deflection of the saw teeth is too small or the saw tooth is passive. 3. When cutting too small diameter wood, the saw blade is sprained badly. 4. Speed of filling wood is too high. 5. The saw blade is too tightened. 6. The saw blade is over warrantable period. 	<ol style="list-style-type: none"> 1. Adjust the guiding board correctly. 2. Reshape the saw route, sharpen the saw teeth. . 3. Reinstall the narrow saw blade to make the saw route wide. 4. Slow the speed of sending materials. 5. Loosen the saw blade properly. 6. Renew the saw blade.



BS14 STAND PARTS

NO.	NAME	Q'TY
1	Support parts	4
2	Hex nut M8	24
3	Washer ø8	28
4	Carriage bolt M8×16	16
5	Connected plate (1)	2
6	Connected plate (2)	2
7	Rubber washer	4
8	Hex bolt M8×40	4

NO.	Description	Q'TY	NO.	Description	Q'TY
1	Column cover	1	41	Hexagon nut M16	1
2	Sawing body	1	43	Motor wheel	1
3	Copper washer	4	44	Washer ø14	1
4	Magnetic switch	1	45	Double-ended screw	3
5	Hexagon head screw M8×20	4	46	Big triangle frame	1
6	Motor	1	47	Rubber belt for saw wheel	2
7	Dust cover	1	48	Semicircle head screw M5×12	1
8	Upper door	1	49	Washer ø10	1
9	Lower door	1	50	Semicircle head screw M6×12	5
10	Thin hexagon head screw nut	B(4)C(3)	51	Frame of guide pole	1
11	Door rolling axis	B(4)C(3)	52	Guide pole	1
12	Spring washer	B(4)C(3)	53	Spacing board	1
13	Case of door rolling axis	B(4)C(3)	54	Tapping screw	4
14	Closing door board	B(4)C(3)	55	Square-necked screw M8×24	5
15	Flat head screw M6×8	B(4)C(3)	58	Square pole end frame	1
16	Semicircle head screw M5×8	6	59	Long hole center seat	1
17	Washer ø5	5	60	Washer ø6	14
18	Spring leaf	2	61	hexagon head screw M6×24	3
19	Hexagon nut M5	2	62	Bearing 80016	4
20	Hand wheel	1	63	Semicircle head screw M4×6	1
21	Semicircle head screw M6×16	1	64	Small safety cover	1
22	Washer ø12	4	65	Stop axis pole	1
23	Guide screw pole	1	66	Guide axle	2
24	Spring	1	67	Semicircle head screw M6×14	2
25	Square nut	1	68	Nut board	1
26	Steel dowel	2	69	Guide frame	1
27	Guide board saddle	2	70	Screw dowel	1
28	Washer ø8	18	71		
29	Hexagon head screw M8×16	4	72	hexagon head screw M6×14	1
30	Upper wheel saddle	1	73	Thumb nut M8	3
31	Small triangular frame	1	74	Stand of upper guide board	1
32	Upper wheel axle	1	75	Stripe-shaper washer	2
33	Adjusting handle M8	1	76	Step bolt M8×50	2
34	Bearing 80203	4	77	Flower nut	2
35	Upper saw wheel	1	78	Step bolt M6×40	2
36	Blade	1	79	Upper guide board	1
37	Axis elastic ring	2	80	hexagon head screw M8×44	1
38	Low saw wheel	1	81	Rubber washer	1

NO.	Description	Q'TY	NO.	Description	Q'TY
40	Low wheel axle	1	82	Guide board	1
83	worktable	1	110	Hexagon screw M6×20	2
84	insert	2	111	Bearing pole	2
85	Board of saw mouth	1	112	Guide frame stand	1
86	Large washer ø6	4	113	Single hole press board	2
87	Side guide board	1	114	Hexagon screw M6×12	2
88	Rotating angle rule	1	115	Thumb bolt	4
89	Stand of worktable	1	116	Hexagon nut M6	6
90	Socket head cap screw M8×20	4	117	Protect board	1
91	Rotating pointer	2	118	Spring washer ø12	3
92	Flower knob M6×18	1	119	Spring washer ø8	8
93	Graduate disc	1	120	Spring	1
94	Washer	4	121	Key	1
95	Rolling fixed frame	1	122	Plastic bush	4
96	Nut	4	123	Fix bush	1
97	Hexagon nut M8	5	124	Lock nail M6×12	1
98	Drawing belt	1	125	Flat nail M5×6	1
99	Circlips for shaft	1	126	hexagon head screw M6×20	1
100	Bearing 80101	2	127	Plastic square washer	1
101	Press wheel	1	128	External teeth washer ø4	6
102	Axle of press wheel	1	129	washer ø4	9
103	Press wheel pole	1	130	Flower knob	
104	Spring pin	1	131	Semicircle head screw M4×30	8
105	Handle of press wheel	1	132	Inter lock switch	2
106	Hexagon screw M6×18	1	133	Hexagon nut M4	4
107	Flat screw M6×18	1			
108	Upper press board	1			
109	Nearing parts for spacing	1			

