

# WOOD BAND SAW

MODEL

CE

BS18 BS20 BS24

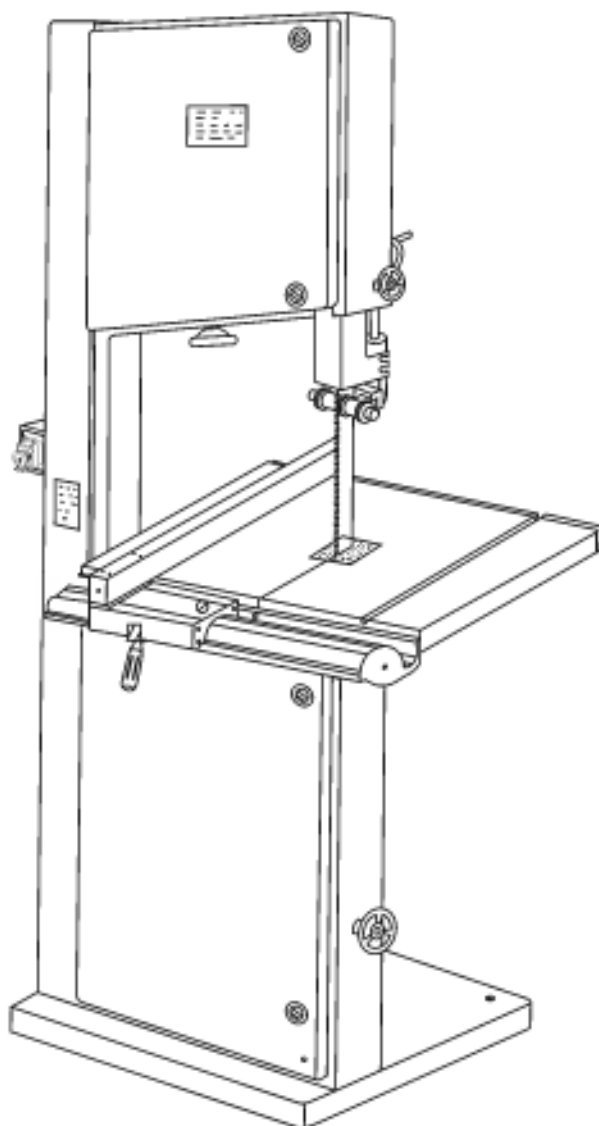

# INSTRUCTION MANUAL

Warning! This manual has been prepared for owner and operators of MJ series woodworking band saw, its purpose, aside from machine operation, is to promote safety through the use accepted correct operating and maintenance procedures. Completely read the safety and maintenance instructions before operating or servicing the machine. To obtain maximum lift and efficiency from your band saw, and to aid in using the machine safely, read this manual thoroughly and follow instructions carefully.

## Table of contents

Warning	Page 1
Table of contents	Page 2
General information	Page 2
Main technical data	Page 2
General safety rules	Page 2-3
Safe working practice	Page 3-4
Additional safe working practice for band saws	Page 4-5
Grounding instruction	Page 5
Installment and adjusting	Page 5-6
Adjusting and use of the band saw	Page 6-8
Trouble shooting	Page 9
Parts list	Page 10-11
Parts diagram	Page 12
Appenix	Page 13-14

## General information

MJ series wood band saw allows operators to perform the following operations consecutively: wood block, plywood, plastic material processing and it is prohibited to process the round timber and its working table can tilt 0° to 20° to guarantee the working accuracy of the work pieces.

1. **WARNING!** When using electric tools basic safety precautions should always be carefully followed to reduce the risk of fire, electric shock and personal injury.

Always use PPE goggles or another eye and ear protection.

2. A residual current device RCD must be used when the machine is operated outdoors and ensure that its dust extraction system equipped must work effectively. The air flow speed around the dust chute should reach 20 m<sup>3</sup>/h for dry wood and 28 m<sup>3</sup>/h for wet wood, and make sure the air suction capacity should reach 20 m<sup>3</sup>/h for dry wood and 28 m<sup>3</sup>/h for wet wood around the dust chute and the diameter of the dust chute is 100 mm.

The saw blade is made from manganese 65 (please see the attached technical data sheet).

## Main technical data

NO	ITEM	MODEL			
		MJ3445(18")	MJ345(20")	MJ346(24")	
1	Diameter of upper and lower saw blade	460 mm	500 mm	600 mm	
2	Distance between the two wheel centers	990 mm	965 mm	1095 mm	
3	Work table tilt angle	0°~45°	0°~45°	0°~45°	
4	Processing capacity	Max height	330 mm	280 mm	310 mm
		Max width	430 mm	460 mm	560 mm
5	Saw blade size	3430x6~25x0.65 mm	3500x10~32x0.65 mm	4080x10~32x0.65 mm	
6	Saw blade speed	10 min/s	10m/s	10m/s	
7	Motor power	1.5 kw	2.2kw	3 kw	
8	Motor phase	Three phase or single phase	Three phase or single phase	Three phase or single phase	
9	Rotation speed	1430 RPM	1430RPM	1430 RPM	
10	Noise level	80dB	80dB	80dB	

## General safety rules

Read all these instructions before attempting to operate this product. Save these instructions for future reference.

1. Keep work areas clear. Cluttered areas and benches invite injuries.
2. Consider work area environment. Do not expose tools to rain. Do not use tools in damp or wet locations. Keep work areas well lit. Do not use tools in the presence of flammable liquids or greases.
3. Guard against electric shock. Avoid body contact with earthed or grounded surfaces.
4. Keep other people away. Do not let other persons, especially children, not involved in the work touch of the tool or the extension lead and keep them away from the work area.
5. Store idle tools. When not in use, tools should be stored in a dry locked-up place, out of reach of children.
6. Do not force the tool. It will do the job better and safer at the rate for which it was intended.
7. Use the right tool. Do not force small tools to do the job of a heavy-duty tool. Do not use tools for purposes not intended, for example, do not use circular saws to cut tree limbs or logs.
8. Dress properly. Do not wear loose clothing or jewelry, they can be caught in moving parts. Non-skid footwear is recommended when working outdoors. Wear protective hair covering to contain long hair.
9. Use protective equipment. Use safety glasses. Use face or dust mask if cutting operations create dust.
10. Connect dust extraction equipment. If devices are provided for the connection of dust extraction and collection equipment, ensure these are connected and properly used.
11. Do not abuse the cable. Never pull the power cable to disconnect it from the socket. Keep the cable from the socket. Keep the cable away from heat, oil and sharp edge.
12. Secure work. If possible use clamps or a vice to hold the work. It is safer than using your hand.
13. Do not over reach. Keep proper footing and balance at all times.
14. Maintain tools with care. Keep cutting tools sharp and clean for better and safer performance. Follow instructions for lubricating and changing accessories. Inspect power cables periodically and if damaged have them replaced by an authorized service facility. Inspect extension cables periodically and replace if damaged. Keep handles dry, clean and free from oil and grease.
15. Disconnect tools. When not in use, before servicing and when changing accessories such as blades, bits, cutters, disconnect tools from the power supply.
16. Remove adjusting keys and wrenches. Form the habit of checking to see that keys and adjusting wrenches are removed from the tool before turning it on.
17. Avoid unintentional starting. Ensure switch is in "OFF" position when plugging in.
18. Use outdoor extension leads intended for outdoor use and so marked.
19. Stay alert. Watch what you are doing, use common sense and do not operate the tool when you are tired.
20. Check damaged parts. Before further use of the tools, it should be carefully checked to determine that it operates properly and perform its intended functions. Check the alignment of moving parts, binding of moving parts, breakage of parts, mounting and any other conditions that may affect its operation. A guard or other part that is damaged should be properly repaired or replaced by an authorized service center unless otherwise indicated in this instruction manual. Do not use the tool if the switch does not turn on and off.
21. Warning! The use of any accessory or attachment other than one recommended in this instruction manual may present a risk of personal injury.

Have your tool repaired by a qualified person. This electric tool complies with the relevant safety rules.

Repairs should only be carried out by qualified technicians by using original spare parts, otherwise this may result in considerable danger to the user.

22. Before starting the machine carefully read the instruction manual to avoid any risks of personal injury.

23. A recommendation that when a transportable machine is intended to be used outdoors (in the open air) a Residual Current Device (RCD) should be used.

24. The using voltage deviation for the machine must be controlled under +/- 10% rated voltage and its frequency deviation must be controlled under +/- 1Hz.

25. The machine is intended for work under the roof if the following conditions are fulfilled. Air temperature: from 5°C to 40°C, relative humidity: from 30% to 95% non-condensing, altitude above sea level: max 1000 meter. The machine should be stored under the roof with air temperature from -25°C to 55°C.

26. A protective fuse GV<sub>2</sub>-RS10, 2.2KW, 4-6.3A should be used.

27. A under voltage protection must be used on the machine.

28. A over voltage protection must be used on the machine.

29. Disconnect the machine from the power supply before perform any maintenance or repairs for the machine.

30. Warning! Before starting the machine, the safety gate must be in proper place.

Use PPE material protective gloves, eye protection and protection ear protection.

Use nontoxic oil.

Do not use damaged blades.

Should any damage to the accessories fixing on the working table happens, the damaged parts should be changed without any delay.

A proper device should be used to hold the work piece to prevent rolling away.

The operator should note the indicating pointer under the working table to adjusting the table when performing angle cutting operations.

Adjusting the blade protection close to the working piece as far as possible.

31. The door can be opened after stop the machine about 15 seconds.

32. Please use forklift to transport the saw to final destination.

## **SAFE WORKING PRACTICE**

1. When the machine is not in use, for example at the end of shift, release the saw blade strain and place a notice on the machine to indicate this and to remind the next user to adjust the strain before starting up.

2. Any change or replacement of the protection cover must be carried out by an authorized place.

3. Machine operation

Never clean the saw blade or band wheel of a band wheel of a band saw using a hand-held brush or scraper while the saw blade is in motion.

4. Noise reduction

Regular maintenance of saw blades, extraction system, cleaning and lubrication of the saw blade etc, is necessary to help control machine noise.

5. Operating training

It is necessary that all operators are adequately trained in the use, adjustment and operation of the machine. This covers in particular.

a) The principles of machines setting and operation, including the correct use, adjustment and operation of work piece holding and guiding devices and guards.

- b) The safe handling of the work piece when cutting.
- c) The use of personal protective equipment for ear and eye protection.

## 6. Tooling

Care should be taken to avoid damaging the saw blade. When not in use, un-tensioned band saw blades should be coiled (See Figure A1) and secured. They should be stored in a safe, dry place. Before use they should be checked for damaged teeth and cracks.

To avoid cracking, tensioned saw blades should be stored in accordance with Figure A2.

At least two operators will be needed to change a wide saw blade.

Suitable carrier equipment should be provided for transporting tensioned wide saw blade(see Figure A2).

Suitable gloves(or other handing aids)should be worn whenever saw blade are handled.

## 7. Lighting

It is important to provide adequate lighting around the machine.

### **Additional safe working practices for band saws**

#### 1. Saw blade thrust wheel

The purpose of the thrust wheel on a table band saw is to give support to the saw blade when cutting. Position it just clear of the saw blade when the saw blade is running free after being strained and tracked. Lack of clearance will cause grooving of the trust wheel and lead to saw blade failure.

#### 2. Machine operation

It is necessary to adjust the adjustable saw blade guard as close to the work piece as practicable.

#### 3. Straight work

Always use a fence for straight cutting, to prevent the work piece rocking or sliding.

When hand feeding against the fence, it is necessary to use a push stick for feeding close to the saw blade.

Use a demountable power feed device whenever possible with table band saws. Not only are they valuable aids to safety, but they also increase the output of the machine.

#### 4. Diagonal cutting

The machines with a fixed table, firm support should be provided by a means of jig when cutting diagonals. It is necessary to use a push stick at the end of the cut.

#### 5. Cutting tenons

In the absence of a tenoning machine, a table band saw provides a safe method of cutting tenons.

#### 6. Wedge cutting

When cutting small wedge on a table band saw it is necessary to use a guide.

#### 7. Curved and irregular work

When cutting curved or irregular work on a table band saw it is necessary to feed the work piece forward evenly while holding it firmly on the table to ensure effective control during cutting and while keeping the hands in a safe position. Alternatively a template can be used.

For repetition work or curved and irregular shapes, a guide fixed in front of the saw blade can be used in conjunction with a template to improve safety as well as the speed of operation.

Do not use re-saws for this type of work.

#### 8. Cross cutting round stock

If cutting round stock is necessary to secure the work piece against rotation by using a jig or holder and

to use a saw blade suitable for cross cutting.

#### 9. Operator training

It essential that all operators are adequately trained in the correct use and adjustment of safety appliances such as jigs, templates and extension tables.

### Grounding instruction

1.This machine is equipped with outside wires and plug including grounding lines and ensure the grounding lines be fixed to the housing of the tool and the remaining two wires must be connected correctly.

2.Should the machine not be grounded correctly, electric shocks will be invited.

3.Should any damages to the wires happen please replace or repair the wires without any delay.

### Installment and adjusting

1. Installment and mounting of the band saw

1.1 Remove the packing material from the band saw.

1.2 Move the saw to its permanent working location. The site should be dry, well lit, and have enough room to handle long stock and the service and/or adjustment of the machine form any side.

1.3 Clean all rust protected surface with a mild solvent or diesel fuel and a soft cloth. Do not use lacquer thinner, paint thinner, or gasoline. These will damage painted surface.

1.4 Mount the band saw on flat floor with four M16 bolts to prevent the band saw tipping down when in operation.

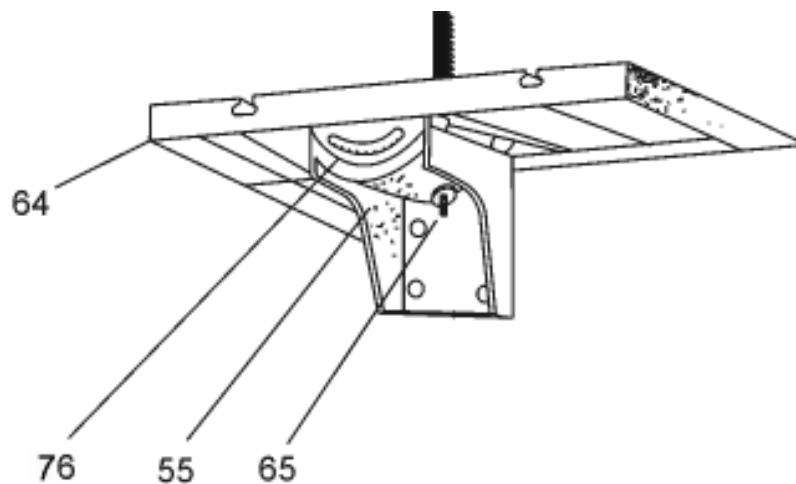
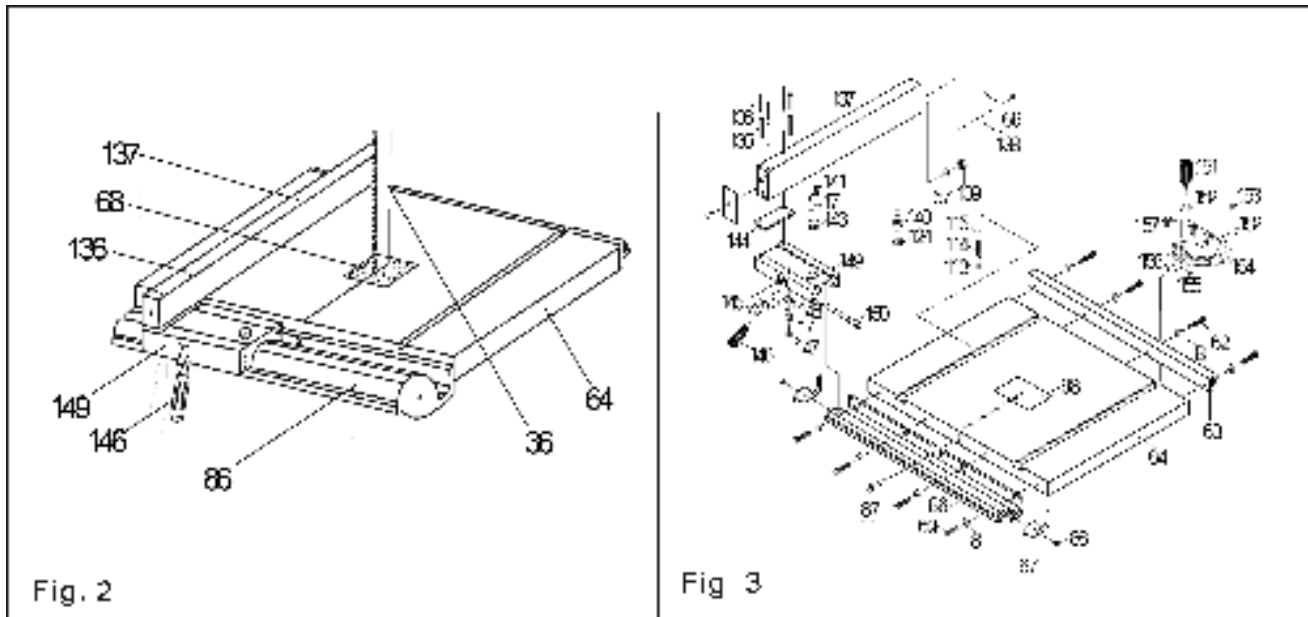

Fig. 1

1.5 Install working table (Part 64)along with the table support(Part 76)on the Inclination support(Part 55) by fixing bolt(Part 65) with the nut.(See Fig. 1)

1.6 Place pin into the center slot on the table and place the insert into the square hole of the working table.

1.7 Mount the fence assembly on the surface of the working table and then loosen the handle (Part 146)and insert the fence base into the guide rail and then lock the handle to secure the upper fence assembly.(See Fig.2 and Fig.3)



- 1.8 If the operator want to place the fence(Part 137) on the other side of the working table, loose the handle, and remove the guide fence, and then slide the fence base to the another side of the working table and secure the guide fence by locking the handle again.
- 1.9 Check the clearance between the table and the fence. The gap should be the same at the front of the table as it is at the rear. If the gap width is different, adjust the foot at the rear of the fence until, the gap with is the same.
- 1.10 Check to see that the pointer is aligned with the zero marking on the guide rail. If adjustment is necessary loosen the screw that holds the pointer in place and line up to the zero mark. Tighten the screw.
- 1.11 The machine is equipped with two brushes, which be used for cleaning the saw blade and lower wheel.
- 1.12 The fence on the table can be fixed on the right or left of the blade.
- 1.13 The max cutting width≤600mm.

**Note: if you can not get the pointer lined up with the zero mark you can slide the guide fence and the guide rail left, or right to achieve the proper setting.**

## Adjusting and use of the band saw

### 1. Wood band saw adjusting and saw blade changing

- 1.1 Generally, the saw blade has been adjusted well before shipment, if the operator wants to change the saw blade, first remove the guide rail and turn the upper wheel, to loose the saw blade and remove the saw blade and change the new one.
- 1.2 After changing the saw blade, turn the upper wheel to tighten the saw blade again and ensure the distortion of the saw blade must be controlled under 8mm+/-10% by supplying 3 kilograms force toward the side edge of the saw blade and make sure the saw blade be perpendicular to the table insert.
- 1.3 Keep in mind that too little, or too much blade tension can cause blade breakage and/or poor cutting performance.
- 1.4 Turning the upper saw blade wheel by hand and adjust the adjusting handle on the back of the saw blade wheel to check the track of the saw blade, ensure the saw blade move the right way around the wheel center.(See Fig.4)

1.5 Adjust the adjusting screws on the triangle support of the lower saw blade wheel support to ensure the saw blade moving and make sure the lower wheel to be parallel to the upper wheel.(See Fig.5)

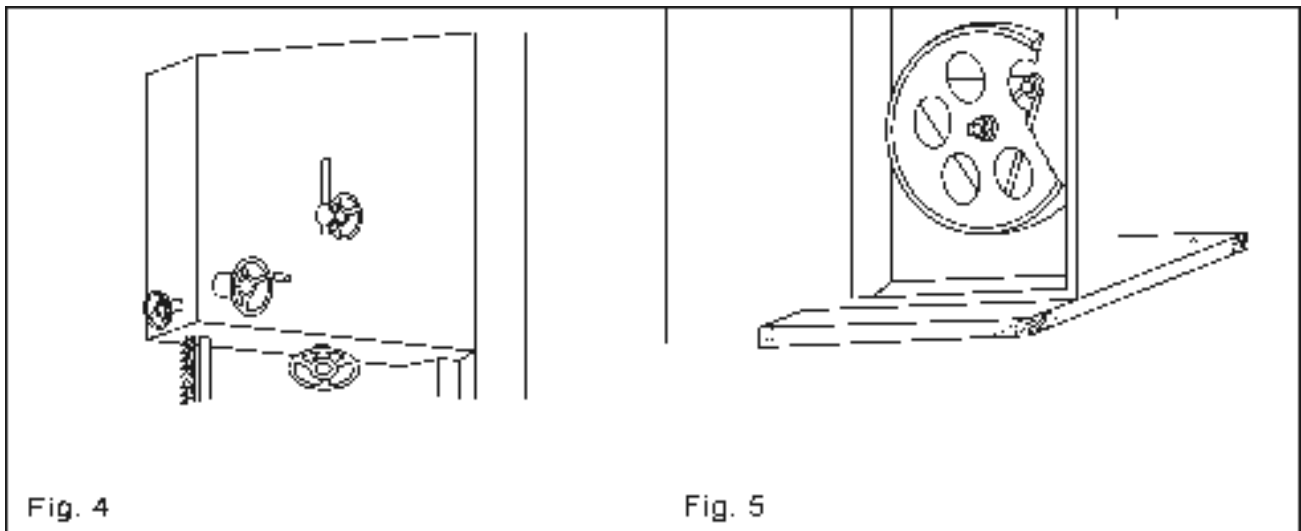

**Note: Blade tracking has been adjusted at the factory. If, however, it is determined that blade tracking needs adjustment and blade must be properly tensioned before adjusting blade tracking. Make sure upper and, lower blade guides do not interfere with the blade while adjusting the tracking.**

## 2. Installment and adjusting of the guide parts

2.1 Blade tension must be properly adjusted prior to blade guide adjusting.

2.2 Upper blade guide adjustment

Loose the Locking knob (part 106) on the side of the upper saw blade wheel support and turn the wheel (part 71) to ensure the guide bar can move up and down freely and lock the knob .Then turn the shaft (Part 112) to adjust the distance between the two guiding wheel and the saw blade and make sure the distance between the blade and the bearing should be controlled under 0.5mm to guarantee the working performance of the band saw. (See Fig.6)

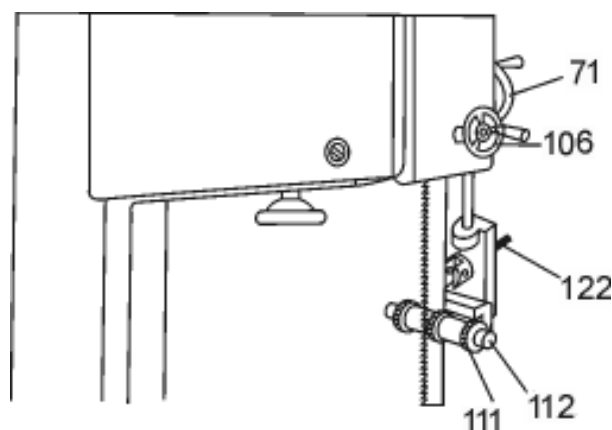

FIG. 6

2.3 Check to make sure the adjustment have not changed and blade guides do not pinch the blade.

## 3. Adjustment of the working table



3.1 Adjusting the bolt on the turning support of the lower saw blade wheel to place the saw blade in the center of the saw blade board mouth and then tighten the bolt.

3.2 Adjusting the locating bolt on the side of the working table to ensure the working table to be vertical to the blade and then tighten the bolt.

3.3 Loosen the thumb nut under the turning support and adjust the working table to the position needed according the angle pointer and then tighten the locking bolt.

#### **4. Cutting height adjustment**

When cutting make sure to put the blade guiding part assembly close to the working pieces as far as possible. Before starting the machine, first loosen the knob and turn the adjusting wheel to move the guiding bar upwards or downwards and make sure to keep the distance between the end of the guiding bar and the working piece to be controlled over about 10mm, and then tighten the locking bolt. The protective cover's movement speed must be lower than 30mm/s.

#### **5. Use of the door safety switch**

The upper and lower doors are both equipped with door safety switch. If the operator wants to open the band saw doors, make sure to switch off the main power and the door safety switch will automatically continue to work about 10 seconds and the doors will not be opened during this period, check the function of safety switch with door open, the machine shall not be started.

#### **6. Brake pedal**

Push the "OFF" button on the power switch of the band saw and then depress the brake pedal and the band saw will stop within 5 seconds. Re-start the saw by pressing the switch.

#### **7. Maintenance of the band saw**

Keep bearing guides clean and free of build up.

Do not let saw dust build up in the upper and lower wheel housing. Vacuum out frequently.

Connect the band saw to a dust collection system.

Clean and grease the raising/lowering rack for the upper bearing guides if it becomes difficult to raise, or lower.

Clean, and oil the tensioning mechanism if it becomes difficult to adjust.

#### **8. Use of the door switch**

The upper and lower doors of the band saw are equipped with door safety switch separately and the doors are opened the band saw will be automatically disconnected from the power source and the band saw will cease to function. If the operator wants to re-start the band saw again close the doors and switch on the band saw again.

## Troubles shooting

Trouble	Possible cause	Solution
Saw stops or will not start	<ol style="list-style-type: none"> <li>1. Overload tripped</li> <li>2. Saw unplugged</li> <li>3. Fuse blown or circuit breaker tripped</li> <li>4. Cord damaged</li> </ol>	<ol style="list-style-type: none"> <li>1. Allow motor to cool and reset by pushing off switch</li> <li>2. Check plug connections</li> <li>3. Replace fuse or reset circuit breaker</li> <li>4. Replace cord</li> </ol>
Does not make accurate 45° or 90° cuts	<ol style="list-style-type: none"> <li>1. Stop not adjusted correctly</li> <li>2. Angle pointer not set accurately</li> <li>3. Miter gauge out of adjustment</li> </ol>	<ol style="list-style-type: none"> <li>1. Check blade with square and adjust stop</li> <li>2. Check blade with square and adjust pointer</li> <li>3. Adjust miter gauge</li> </ol>
Blade wanders during cut	<ol style="list-style-type: none"> <li>1. Fence not aligned with blade</li> <li>2. Warped wood</li> <li>3. Excessive feed rate</li> <li>4. Incorrect blade for cut</li> </ol>	<ol style="list-style-type: none"> <li>1. Check and adjust fence</li> <li>2. Select another piece of wood</li> <li>3. Reduce feed rate</li> <li>4. Change blade to correct type</li> </ol>
Saw makes unsatisfactory cuts	<ol style="list-style-type: none"> <li>1. Dull blade</li> <li>2. Blade mounted wrong</li> <li>3. Gum or pitch on blade</li> <li>4. Incorrect blade for cut</li> <li>5. Gum or pitch on table</li> </ol>	<ol style="list-style-type: none"> <li>1. Replace blade</li> <li>2. Teeth should point down</li> <li>3. Remove blade and clean</li> <li>4. Change blade to correct type</li> <li>5. Clean table</li> </ol>
Blade does not come up to speed	<ol style="list-style-type: none"> <li>1. Extension cord too light or too long</li> <li>2. Low shop voltage</li> </ol>	<ol style="list-style-type: none"> <li>1. Replace with adequate size cord</li> <li>2. Contact your local electric company</li> </ol>
Saw vibrate excessively	<ol style="list-style-type: none"> <li>1. Base on uneven floor</li> <li>2. Bad v-belt</li> <li>3. Bent pulley</li> <li>4. Improper motor mounting</li> <li>5. Loose hardware</li> </ol>	<ol style="list-style-type: none"> <li>1. Reposition on flat, level surface</li> <li>2. Replace v-belt</li> <li>3. Replace pulley</li> <li>4. Check and adjust motor</li> <li>5. Tighten hardware</li> </ol>

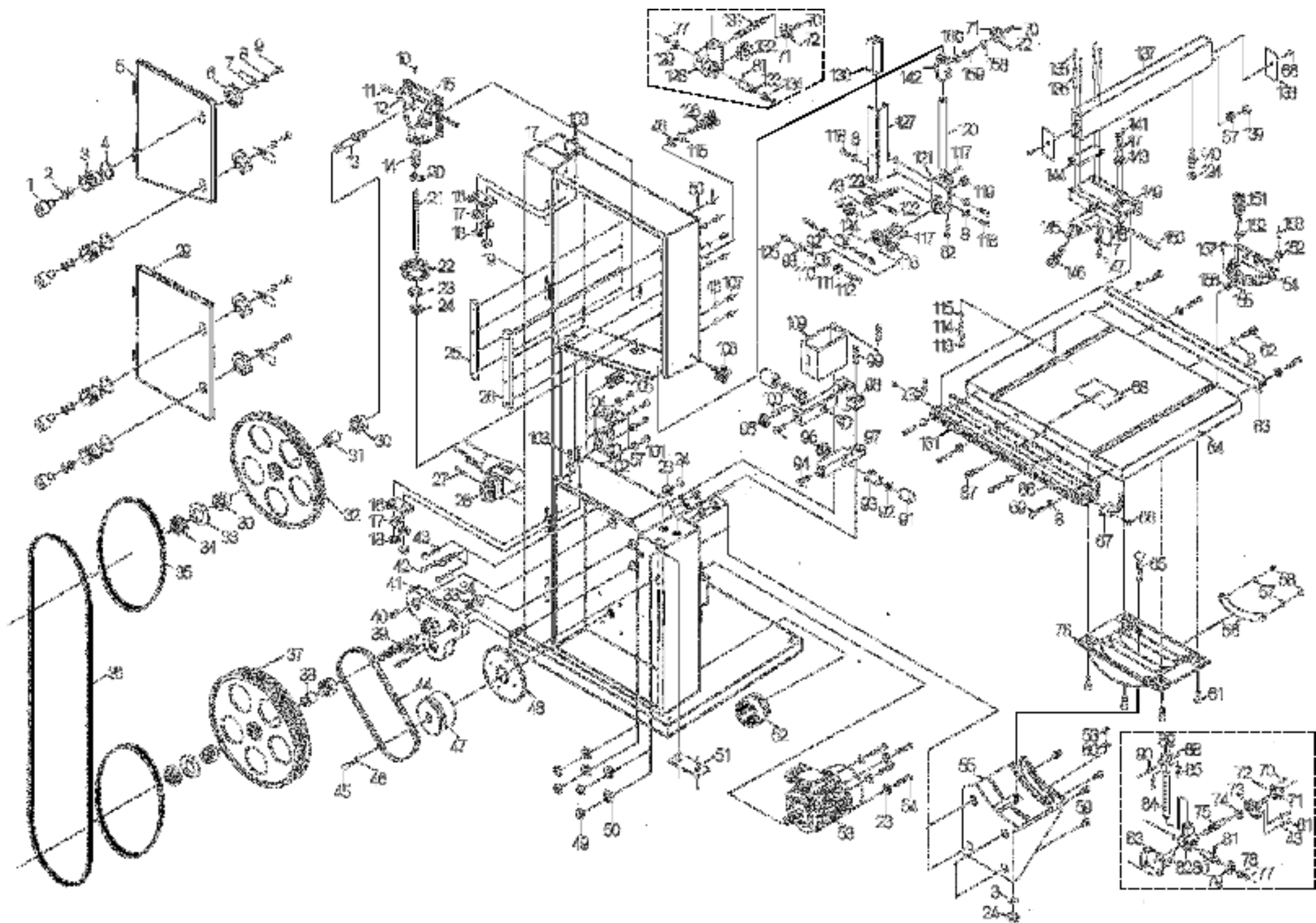

## PARTS LIST

Item	Description	Q'TY	Item	Description	Q'TY
1	Door axel	4	40	Adjusting screw	3
2	Washer 10	8	41	Lower wheel support	1
3	Door axel bush	4	42	Hex bolt M8x20	4
4	Plastic washer	4	43	Washer 8	8
5	Upper door	1	44	V-belt	2
6	Plastic nut	4	45	Hex bolt M8x30	1
7	Door lock plate	4	46	Washer 8	1
8	Washer 6	15	47	Motor pulley	1
9	Hex bolt M6x8	4	48	Motor mounting plate	1
10	Pin 5x25	1	49	Hex nut M10	4
11	Adjusting shaft	2	50	Washer 10	4
12	Upper wheel shaft base	1	51	Plate	1
13	Upper wheel shaft	1	52	Dust chute	1
14	Spring	1	53	Motor	1
15	Upper wheel adjusting base	1	54	Hex bolt M12x35	4
16	Safety switch	2	55	Inclination support	1
17	Washer 4	11	56	Scale plate	1
18	Hex nut M4	4	57	Washer 5	8
19	Saw body	1	58	Phillips head screw M5x6	3
20	Nut	1	59	Adjusting screw	4
21	Adjusting thread bar	1	60	Pointer	1
22	Handwheel	1	61	Cap screw M8x25	4
23	Washer 12	5	62	Cap screw M6x12	5
24	Hex nut M12	5	63	Back rail	1
25	Left adjusting base	1	64	Working table	1
26	Right adjusting base	1	65	Flange bolt	1
27	Phillips head screw M4x60	4	66	Phillips head tap screw 3x10	4
28	Switch	1	67	Side clamp plate	2
29	Lower door	1	68	Table insert	1
30	Bearing 80206	4	69	Hex bolt M8x16	4
31	Upper wheel shaft bush	1	70	Handle	2
32	Upper wheel	1	71	Handwheel	2
33	Washer 24	3	72	Cap screw M6x10	2
34	Hex nut M24	3	73	Plate	1
35	Rubber belt	2	74	Bearing 101	3
36	Saw blade	1	75	Worm	1
37	Lower wheel	1	76	Table support	1
38	Lower wheel shaft bush	1	77	C' ring 10	4
39	Lower wheel shaft	1	78	Plate	1
79	Gear	1	120	Guide bar	1

<b>Item</b>	<b>Description</b>	<b>Q'TY</b>	<b>Item</b>	<b>Description</b>	<b>Q'TY</b>
80	Gear shaft	1	121	Guide bar bracket	1
81	Pin 4x12	2	122	U-shaped bracket	1
82	Gear box	1	123	Shaft	1
83	Gear	1	124	Bearing 80027	2
84	Rack	1	125	Upper Guide wheel	2
85	Cap screw M6x16	2	126	Adjusting handle	1
86	Front guiding rail	1	127	Protection guard	1
87	Pin	1	128	Guide base	1
88	Pin 2x12	1	129	Gear bush	1
89	Support	4	130	Sliding plate	1
90	Shaft	1	131	Worm	1
91	Lower guide shaft	2	132	Gear	1
92	C' ring 10	4	133	Gear shaft	1
93	Lower guide copper bush	4	134	bush	1
94	Phillips head screw M6x12	3	135	Bush	4
95	Bearing 80101	1	136	Cap screw M6x65	4
96	Lower guide wheel	2	137	Upper guide plate	1
97	Lower guide base	1	138	Upper guide plate insert	2
98	Lower guide base	1	139	Hex nut M5	1
99	Cap screw M6x40	2	140	Bearing bar	1
100	Eccentric bearing shaft	1	141	Phillips head screw M4x5	1
101	Phillips head screw M5x10	4	142	Guide bar base	1
102	Contactora	1	143	Pointer with magnifier	1
103	Phillips head screw M4x30	4	144	Plate	1
104	Contactora box	1	145	Locking block	1
105	Retainer M20x15	5	146	Locking handle	1
106	Locking knob	1	147	Phillips screw M4x8	1
107	Hex bolt M8x12	2	149	Sliding base	1
108	Hex bolt M10x25	10	150	Shaft	1
109	Lower protection guard	1	151	Handle	1
110	Blade guide base	2	152	Washer 6	2
111	Nut	2	153	Phillips head screw M6x6	1
112	Adjusting shaft	2	154	Scale for mitre gauge	1
113	Rubber plate	1	155	Cap screw M4x6	1
114	Hex bolt M8x25	1	156	Slide plate	1
115	Hex nut M8	2	157	Round pointer	1
116	Blade guide support	1	158	Bearing	1
117	Cap screw M8x12	2	159	Gear	1
118	Phillips head screw M6x10	2	160	Washer	1
119	Locking nut	1	161	Scale for front guiding rail	1

## Adjustment of the lower saw blade guide

1. The part of lower saw blade guide is mounted on the lower wheel support by two bolts, should the operator wants to change or adjust the saw blade, loosen the socket head cap screw M8x12 (Part 107) and slide the guide tip bar until the guide tip just behind the gullet of the blade teeth and the back-up bearing also should be readjusted. Make sure the guide tip is 0.003" away from the side of the blade, about the thickness of a piece of paper.

Adjust the opposite side guide tip.

2. Check to make sure the adjustments have not changed and the guide tips do not pinch the blade.

Part No	Description	Quantity
101	Upper saw blade guide base	1
102	Lower saw blade guide base	1
103	Copper bush	2
104	Steel bar	2
105	Plats	1
106	Guide tip	2
107	Socket head cap screw M8x12	2
108	Ball bearing	1
109	Ball bearing bar	1
110	Socket head cap screw M8x40	2
111	Socket head cap screw M8x16	1

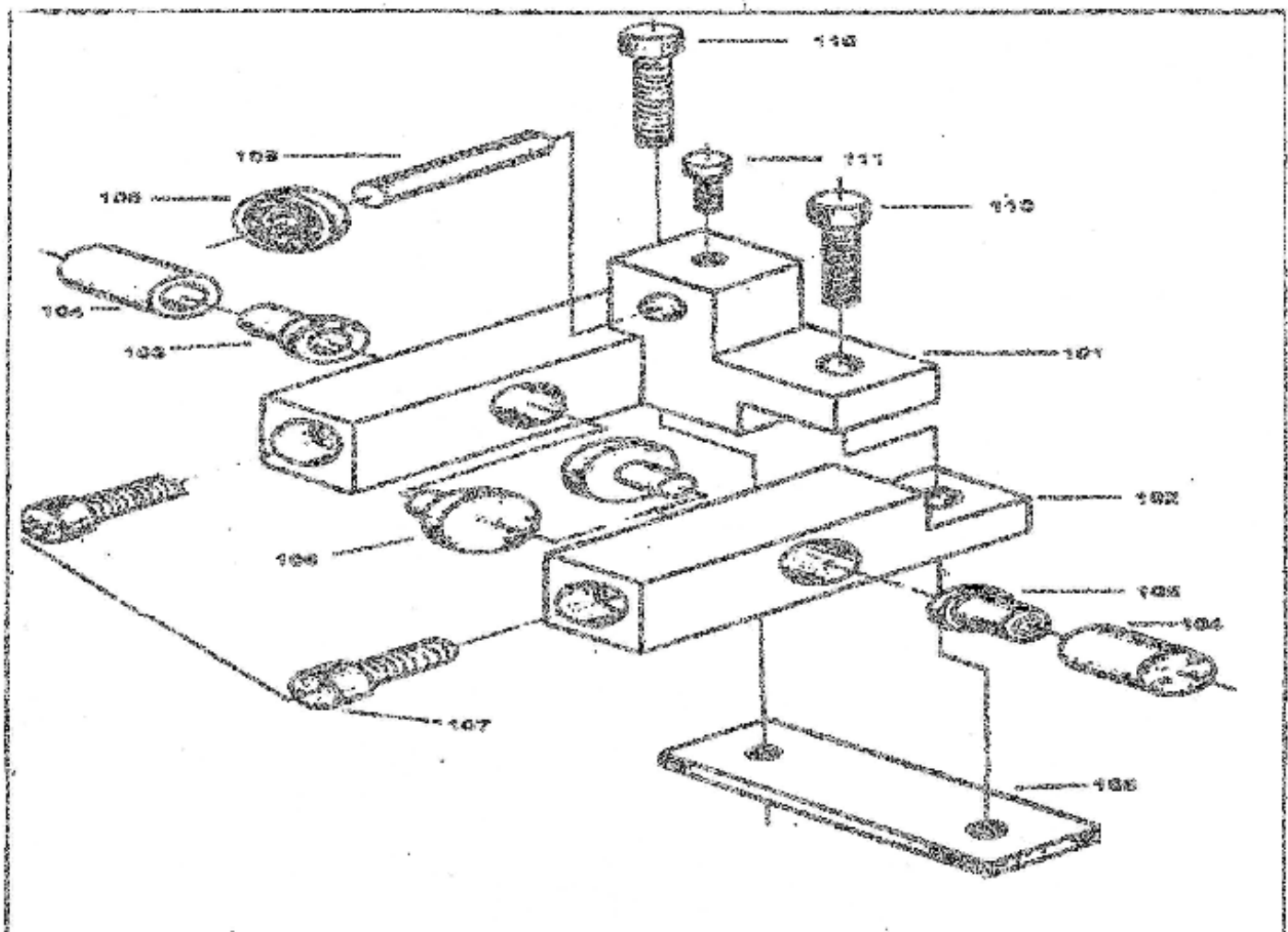

PART NO.	DESCRIPTION	QTY	PART NO.	DESCRIPTION	QTY
C50	Handle	1	C58	Guide plate	1
C51	Ball bearing	1	58-1	Bush	2
C52	Gear	1	58-2	Nut	2
C53	Guide bar base	1	58-3	Bolt	2
C54	Upper saw blade protection plate	1	58-4	Pin	2
C55	Guide bar	1	58-5	Guide wheel	2
C56	Guide bar bracket	1	C60	U-shaped bracket	1
C57	Nut M8	1	60-1	Pin	1
C65	Brake pedal	1	60-2	Cring	1
C68	Brake shaft	1	60-3	Ball bearing	1
C73	Brake holder block	1	60-4	Bush	1
C83	Upper wheel mounting shaft	1			

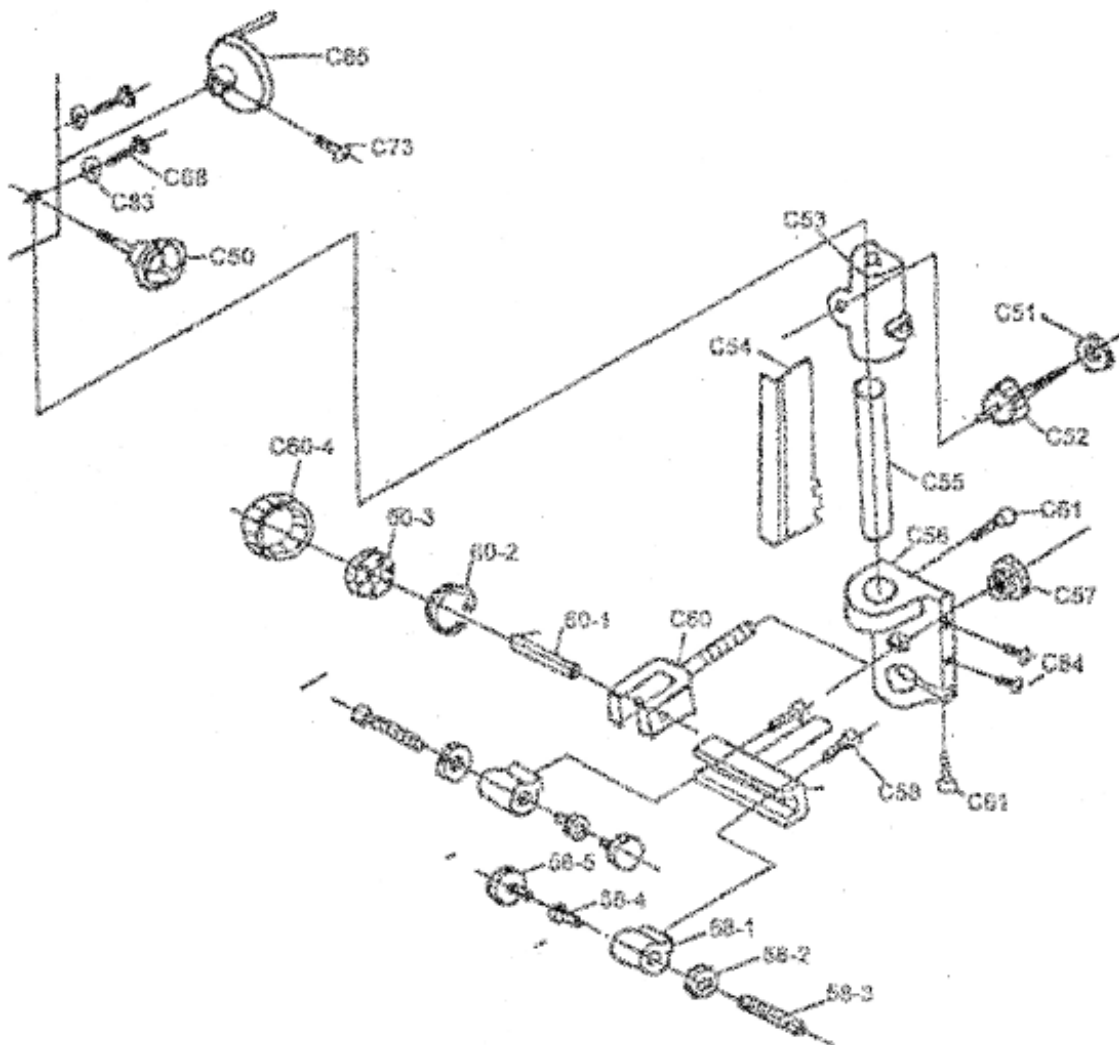

# WORKING TABLE CABINET FOR

# SAND BAY

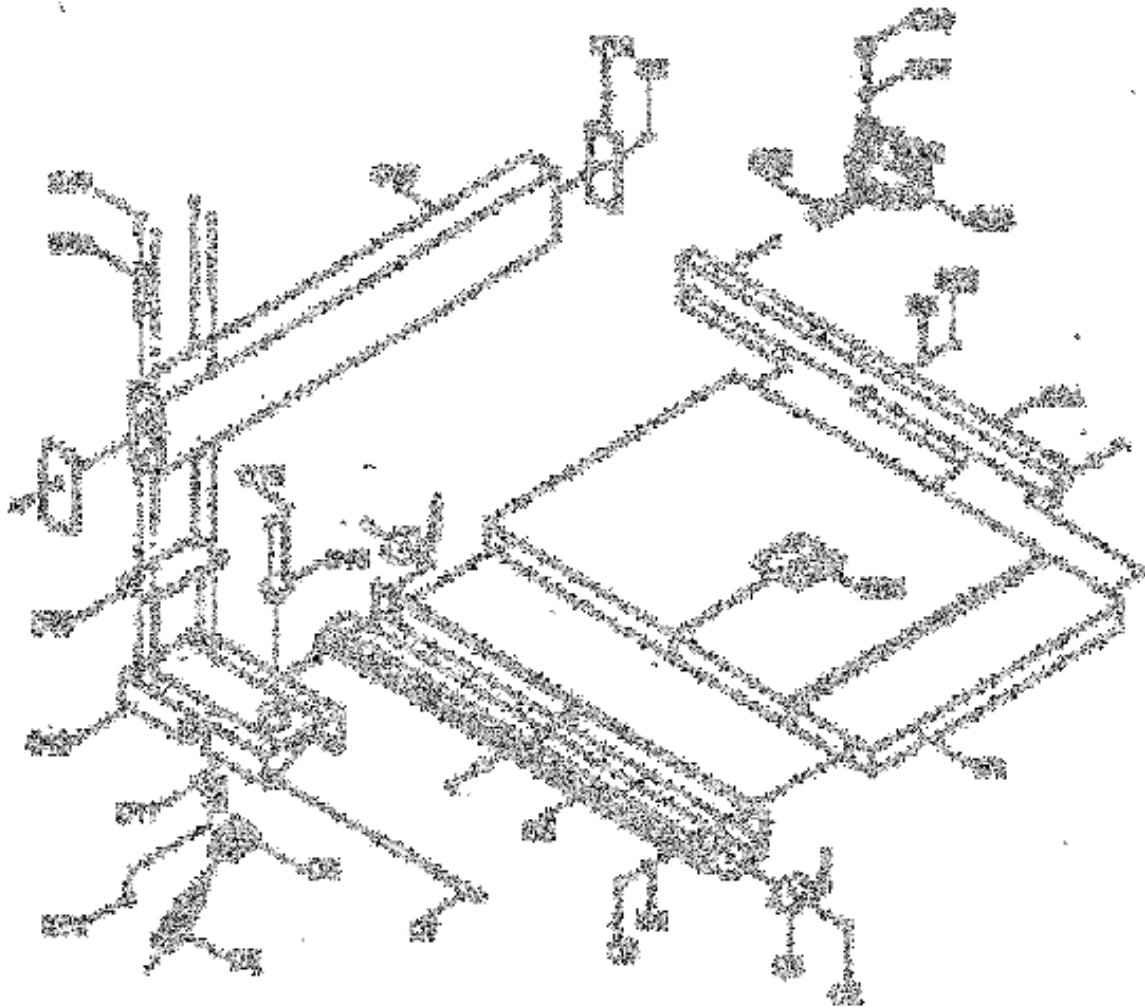

QTY	NO.	DESCRIPTION	QTY	NO.	DESCRIPTION	QTY
1	1	TABLE TOP	1	1	TABLE TOP	1
1	2	FRONT DRAWER	1	2	FRONT DRAWER	1
1	3	BACK DRAWER	1	3	BACK DRAWER	1
1	4	TABLE LEG	1	4	TABLE LEG	1
1	5	TABLE LEG	1	5	TABLE LEG	1
1	6	TABLE LEG	1	6	TABLE LEG	1
1	7	TABLE LEG	1	7	TABLE LEG	1
1	8	TABLE LEG	1	8	TABLE LEG	1
1	9	TABLE LEG	1	9	TABLE LEG	1
1	10	TABLE LEG	1	10	TABLE LEG	1
1	11	TABLE LEG	1	11	TABLE LEG	1
1	12	TABLE LEG	1	12	TABLE LEG	1
1	13	TABLE LEG	1	13	TABLE LEG	1
1	14	TABLE LEG	1	14	TABLE LEG	1
1	15	TABLE LEG	1	15	TABLE LEG	1
1	16	TABLE LEG	1	16	TABLE LEG	1
1	17	TABLE LEG	1	17	TABLE LEG	1
1	18	TABLE LEG	1	18	TABLE LEG	1
1	19	TABLE LEG	1	19	TABLE LEG	1
1	20	TABLE LEG	1	20	TABLE LEG	1
1	21	TABLE LEG	1	21	TABLE LEG	1
1	22	TABLE LEG	1	22	TABLE LEG	1
1	23	TABLE LEG	1	23	TABLE LEG	1
1	24	TABLE LEG	1	24	TABLE LEG	1
1	25	TABLE LEG	1	25	TABLE LEG	1
1	26	TABLE LEG	1	26	TABLE LEG	1
1	27	TABLE LEG	1	27	TABLE LEG	1
1	28	TABLE LEG	1	28	TABLE LEG	1
1	29	TABLE LEG	1	29	TABLE LEG	1
1	30	TABLE LEG	1	30	TABLE LEG	1
1	31	TABLE LEG	1	31	TABLE LEG	1
1	32	TABLE LEG	1	32	TABLE LEG	1
1	33	TABLE LEG	1	33	TABLE LEG	1
1	34	TABLE LEG	1	34	TABLE LEG	1
1	35	TABLE LEG	1	35	TABLE LEG	1
1	36	TABLE LEG	1	36	TABLE LEG	1
1	37	TABLE LEG	1	37	TABLE LEG	1
1	38	TABLE LEG	1	38	TABLE LEG	1
1	39	TABLE LEG	1	39	TABLE LEG	1
1	40	TABLE LEG	1	40	TABLE LEG	1
1	41	TABLE LEG	1	41	TABLE LEG	1
1	42	TABLE LEG	1	42	TABLE LEG	1
1	43	TABLE LEG	1	43	TABLE LEG	1
1	44	TABLE LEG	1	44	TABLE LEG	1
1	45	TABLE LEG	1	45	TABLE LEG	1
1	46	TABLE LEG	1	46	TABLE LEG	1
1	47	TABLE LEG	1	47	TABLE LEG	1
1	48	TABLE LEG	1	48	TABLE LEG	1
1	49	TABLE LEG	1	49	TABLE LEG	1
1	50	TABLE LEG	1	50	TABLE LEG	1
1	51	TABLE LEG	1	51	TABLE LEG	1
1	52	TABLE LEG	1	52	TABLE LEG	1
1	53	TABLE LEG	1	53	TABLE LEG	1
1	54	TABLE LEG	1	54	TABLE LEG	1
1	55	TABLE LEG	1	55	TABLE LEG	1
1	56	TABLE LEG	1	56	TABLE LEG	1
1	57	TABLE LEG	1	57	TABLE LEG	1
1	58	TABLE LEG	1	58	TABLE LEG	1
1	59	TABLE LEG	1	59	TABLE LEG	1
1	60	TABLE LEG	1	60	TABLE LEG	1
1	61	TABLE LEG	1	61	TABLE LEG	1
1	62	TABLE LEG	1	62	TABLE LEG	1
1	63	TABLE LEG	1	63	TABLE LEG	1
1	64	TABLE LEG	1	64	TABLE LEG	1
1	65	TABLE LEG	1	65	TABLE LEG	1
1	66	TABLE LEG	1	66	TABLE LEG	1
1	67	TABLE LEG	1	67	TABLE LEG	1
1	68	TABLE LEG	1	68	TABLE LEG	1
1	69	TABLE LEG	1	69	TABLE LEG	1
1	70	TABLE LEG	1	70	TABLE LEG	1
1	71	TABLE LEG	1	71	TABLE LEG	1
1	72	TABLE LEG	1	72	TABLE LEG	1
1	73	TABLE LEG	1	73	TABLE LEG	1
1	74	TABLE LEG	1	74	TABLE LEG	1
1	75	TABLE LEG	1	75	TABLE LEG	1
1	76	TABLE LEG	1	76	TABLE LEG	1
1	77	TABLE LEG	1	77	TABLE LEG	1
1	78	TABLE LEG	1	78	TABLE LEG	1
1	79	TABLE LEG	1	79	TABLE LEG	1
1	80	TABLE LEG	1	80	TABLE LEG	1
1	81	TABLE LEG	1	81	TABLE LEG	1
1	82	TABLE LEG	1	82	TABLE LEG	1
1	83	TABLE LEG	1	83	TABLE LEG	1
1	84	TABLE LEG	1	84	TABLE LEG	1
1	85	TABLE LEG	1	85	TABLE LEG	1
1	86	TABLE LEG	1	86	TABLE LEG	1
1	87	TABLE LEG	1	87	TABLE LEG	1
1	88	TABLE LEG	1	88	TABLE LEG	1
1	89	TABLE LEG	1	89	TABLE LEG	1
1	90	TABLE LEG	1	90	TABLE LEG	1
1	91	TABLE LEG	1	91	TABLE LEG	1
1	92	TABLE LEG	1	92	TABLE LEG	1
1	93	TABLE LEG	1	93	TABLE LEG	1
1	94	TABLE LEG	1	94	TABLE LEG	1
1	95	TABLE LEG	1	95	TABLE LEG	1
1	96	TABLE LEG	1	96	TABLE LEG	1
1	97	TABLE LEG	1	97	TABLE LEG	1
1	98	TABLE LEG	1	98	TABLE LEG	1
1	99	TABLE LEG	1	99	TABLE LEG	1
1	100	TABLE LEG	1	100	TABLE LEG	1



Wire Diagram, three phase, with safety switch



Wire Diagram, single phase, with safety switch



Wire Diagram, three phase



Wire Diagram, single phase

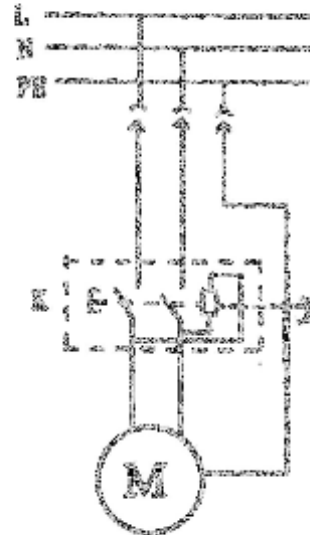

Wire Diagram, three phase, with contactor

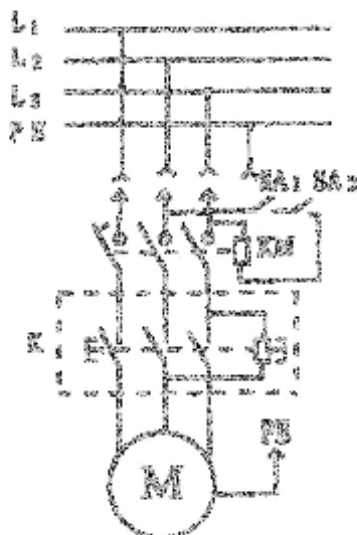

Wire Diagram, single phase, with contactor

